

## Manual Stair Robot SR EXPRESS



---

## Stairrobot

Type number : SR EXPRESS  
Serial number :  
Year of construction : 2007  
Owner :



**AATA International b.v**  
Kerkstraat 79  
2777 AX Oude wetering  
The Netherlands

Tel : 0031-(0) 713310336  
Fax : 0031-(0) 713317243

e-mail: [info@aata.nl](mailto:info@aata.nl)  
<http://www.aata.nl>

No part of this publication may be reproduced, stored in a retrieval system or transmitted in any form or by any means, electronic, mechanical, photocopying, recording or otherwise without the written permission of AATA International b.v. The content of this manual is subject to change without notice. Product specification and design are subject to change without notice.

## **Preface**

AATA International is an innovative and dynamical company, specialised in stair climbing equipment. Stairrobots are active in over 30 countries worldwide.

This manual is written for operators and for technician. Although the tiniest details are not set out, the manual is a useful help for people who are dealing with the machine on a daily basis.

The stairrobot SR EXPRESS is a battery-powered stair climbing device designed for day-to-day distribution

The stairrobot SR EXPRESS can handle unit loads weighing up to 150 kg up- and down stairs.

Read this manual carefully before putting the SR EXPRESS into operation. Always take note of the safety rules as mentioned in chapter “safety”.

A copy of this manual should be kept with the machine, so the operator has it at his disposal.

AATA International b.v.

---

## Table of contents

|   |           |
|---|-----------|
| Preface.....                                | 3         |
| Table of contents .....                     | 4         |
| Survey of standards.....                    | 5         |
| <b>1. Technical data.....</b>               | <b>6</b>  |
| <b>2. Description main components .....</b> | <b>7</b>  |
| <b>3. Battery charger .....</b>             | <b>8</b>  |
| <b>4. Battery-pack .....</b>                | <b>9</b>  |
| <b>5. Safety</b>                            |           |
| 5.1 General safety precaution.....          | 10        |
| <b>6. Operators procedure</b>               |           |
| 6.1 Positioning of drive-unit .....         | 12        |
| 6.2 Controls .....                          | 13        |
| 6.3 Rotating arm .....                      | 13        |
| 6.4 Pre-use inspection .....                | 14        |
| 6.5 Loading .....                           | 14        |
| 6.5.1 The correct position of the load..... | 14        |
| 6.5.2 Loading procedure .....               | 16        |
| 6.6 Ascending .....                         | 17        |
| 6.6.1 Landing.....                          | 18        |
| 6.7 Descending .....                        | 19        |
| 6.8 Unloading .....                         | 20        |
| <b>7. Trouble shooting chart.....</b>       | <b>21</b> |
| <b>8. Track replacement .....</b>           | <b>22</b> |
| <b>9. CD-Rom video .....</b>                | <b>23</b> |

## Survey of standard

We declare that the construction of the stairrobot SR Express is according to the provisions of EC-Directives 89/392/EWG.



Applied harmonized standard:

NEN-EN 60034-5; NEN 10034-6; NEN 10072-2

Applied national standards, directives and technical specifications:

IEC 34-5; IEC 34-7; IEC 72-1

## Survey of symbols

|   |   |
|---|---|
|  | <p>Not (or not completely) observing the operating instructions can lead to serious accidents or damage</p> |
|  | <p>Danger as a result of electric tension</p>   |

|  |  |
|--|--|
|   |  |
| <p><b>EG-VERKLARING VAN OVEREENSTEMMING</b><br/> <b>EC-DECLARATION OF CONFORMITY</b><br/> <b>EG-KONFORMITÄTS ERKLÄRUNG</b><br/> <b>EG-DÉCLARATION DE CONFORMITÉ</b></p>  |  |
| <p>Hierbij verklaren wij, dat de bouwwijze van de/het product(en)<br/> <i>We declare that the construction of the product(s)</i><br/>                 Hiermit erklären wir daß die Bauart der(s) Produkte(s)<br/> <i>Nous déclarons que le(s) produit(s)</i></p>   |  |
| <p>Identiteit / Identity machine(s) :<br/> <b>STAIR ROBOT SR EXPRESS</b><br/>                 capaciteit : 150 KG Capacity 150 KG</p>  |  |
| <p>conform de bepalingen van de EG-Machine richtlijn 89/392/EWG is<br/> <i>is according to the provisions of the EC-Directives Machinery 89/392/EEC</i><br/>                 entsprechend den Bestimmungen der EG-Richtlinien Maschinen 89/392/EWG ist<br/> <i>est conforme à la norme CE-Directive des Machines 89/392/CE</i></p>                     |  |
| <p><b>Beoordeelde geharmoniseerde normen :</b><br/> <i>Applied harmonized standards:</i><br/>                 Angewandte harmonisierte Normen:<br/> <i>Appliquées normes harmonisées :</i></p>   |  |
| <p><b>NEN-EN 60034-5 ; NEN 10034-6 ; NEN 10072-2</b></p>   |  |
| <p><b>Beoordeelde nationale normen, richtlijnen en technische specificatie:</b><br/> <i>Applied national standards, directives and technical specifications:</i><br/>                 Angewandte nationale Normen, Richtlinien und technische Spezifikationen:<br/> <i>Normes nationales, directives et spécifications techniques appliquées :</i></p> |  |
| <p><b>IEC 34-5 ; IEC 34-7 ; IEC 72-1</b></p>   |  |
| <p>Budel,                      15 April 2004</p>   |  |
|  | <p>handtekening / Signature<br/>                 AATA International bv</p>           |
| <p>AATA International bv<br/>                 Willem II straat 1e<br/>                 60 21EA Budel<br/>                 The Netherlands</p>  |  |

## 1. Technical data:

### Capacity:

- ❖ Maximum capacity flat on staircase max 35° **175 kg**
- ❖ Maximum capacity step by step **150 Kg**
- ❖ Maximum capacity lifting platform **175 kg** (*in straight position 100 Kg*)
- ❖ Speed position 1 7,5 mtr/p/min
- ❖ Speed position 2 4,5 mtr/p/min

### Dimensions

- ❖ Dimensions chassis (L) x (W) x (H) 1445x400x240 mm
- ❖ Wheelbase (W) x (H) x (T) 550x 250x80 mm
- ❖ Dimensions drive unit (L) x (W) x (H) 640x330x120 mm
- ❖ Platform (W x L) 390x290 mm
- ❖ Weight ( without batteries) 29 kilo

### Electrical system

- ❖ 24 volt
- ❖ 2 fast removable battery packs 12v/ 9 ah
- ❖ 250 watt motor
- ❖ Charging time batteries +/- 4 hrs
- ❖ Universal charger 220/110/100 V / 24V 1,5 ah
- ❖ Programmable motor controller

### General

- ❖ Key-switch
- ❖ Battery indicator
- ❖ Positional drive unit
- ❖ Double control position
- ❖ Two-speed operation
- ❖ Heavy duty caterpillar tracks
- ❖ Two-way operation on stairs
  1. Step by step
  2. Flat on the staircase resting on two or more steps
- ❖ Lightweight aluminum chassis
- ❖ Stainless steel suspension
- ❖ Large air tires
- ❖ Capable of climbing straight stairs as well as quarter round stairs
- ❖ Move a load direct out of a van or pick-up truck

### Options

- ❖ Adjustable platform
- ❖ Additional battery pack
- ❖ Remote control
- ❖ Solid rubber tires (also in grey)  $\varnothing$  250 mm en  $\varnothing$  160 mm
- ❖ Rubber protecting straps
- ❖ Truck charger
- ❖ Rigging

## 2 Description main components stairrobot Express

|  |  |
|--|--|
|  | <ol style="list-style-type: none"> <li>1. Controls</li> <li>2. Frame-grip</li> <li>3. Winch</li> <li>4. Control bar</li> <li>5. Die cast aluminum Hinge</li> <li>6. Connection slide-plate</li> <li>7. lift-plate</li> <li>8. Toe-plate</li> <li>9. Adjustable gas spring</li> <li>10. Gas spring handle</li> <li>11. Unit-grip</li> <li>12. Rubber caterpillar tracks</li> <li>13. Removable battery pack</li> <li>14. Fuse box : 1x 32V 30A flat fuse</li> <li>15. Large air tire</li> </ol> |
|  | <ol style="list-style-type: none"> <li>1. Battery-indicator</li> <li>2. Control led</li> <li>3. Charger socket</li> <li>4. Key-switch</li> </ol>   |

### 3. Battery charger

#### Technical data:

- Totally Automatic Switch-Mode Battery Charger
- Suitable for use anywhere in the world.
- Input 115/230 VAC (range 90 VAC to 264 VAC) (47-63Hz)
- Automatic Cut Off and then True Float. Can be left connected indefinitely without harming the battery.
- Two color LED to indicate charge status
- UL, CSA, CE, TUV, GS & T-mark (Japan) Listed
- Meets <> FCC Class B; EN55022 Class B
- Size: Length 4.7 (119mm) Width 2.9 (73) Height 1.6 (41mm)
- Weight 14 ounces (400grams)
- Zero Current Drain when AC power is off
- Protection provided: Reverse Polarity, Short Circuit, Over-Voltage, Over Current and AC Surge. Soft Start and Stop <> Starts and stops gradually. No sudden in-rush of current. This protects both the batteries and any other circuits connected to the charger.

#### Operation:

Start by plugging the charger plug in the charging socket of the SR Express. Connect charger with main circuit. The charger will start the following charging cycle:

#### Stage 1: Deep Discharge Charging Pulse Mode

The Charger starts charging at 0.5V and give pulse current up to 5V. This has effect of removing loose sulphation formed during deep discharge state of the battery.

#### Stage 2: Constant Current Mode (CC)

The charger changes to constant current 1.5A. When the battery voltage reaches up to 28.8V, the charging stage changes from (CC) Constant Current to CV (Constant Voltage) mode.

#### Stage 3: Constant Voltage Mode (CV)

The charger holds the battery at 28.8V and the current slowly reduces. When the current reaches at 0.5 C (C= Battery Capacity), this point called the Switching Point

#### Stage 4: Standby Voltage Mode

The charger maintains the battery voltage at 27.6V and current slowly reduces to zero. Charger can be left connected indefinitely without harming the battery.

#### Recharging:

If the battery voltage drops to 27.6V, the charger changes from any mode to Constant Current mode and restart charging. The charging cycle will go through Stage 2 to Stage 4.

To disconnect the plug from the socket press the release pin on the socket.

**Always connect machine with charger if not in use. Charger can be left connected indefinitely without harming the battery.**

## 4. Battery pack

The SR Express is equipped with a dual battery-pack. 2 x 12V packs rating 24V 9ah.

The battery packs can be easily removed and replaced.:

Turn switch-key off

Unlock battery pack; turn both bolts 90°

Remove battery-pack from the drive unit

Disconnect plugs

To install : reverse operation



Important: to avoid damage to batteries and drive unit please note that when connecting a battery pack the red connector of the battery pack needs to be connected with the red connector of the drive unit and the black connector of the battery pack needs to be connected to the black connector of the drive unit.

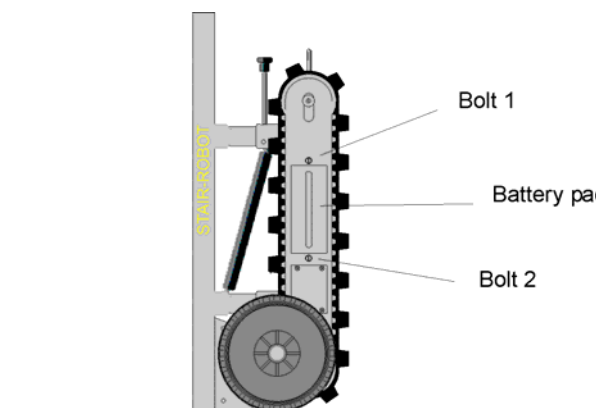

## 5. Safety

### 5.1. General safety precaution



- It is not permitted to make alterations to the machine.
- Everybody who is working with the machine has to be acquainted with the safety rules and has to act upon them.
- Always check the surroundings for safety where the stair-robot will be deployed.
- Assure that the angle of the stairs is not more than 45 °



- Make sure that no operator or other person is underneath the (loaded) Stairrobot during operation



- Secure the working area using warning boards or blocking ribbon

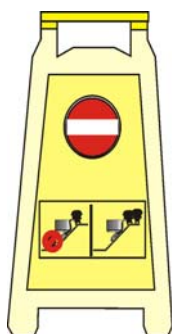



- To avoid misuse by any unauthorized persons, don't leave the machine unattended.
- Within the path of the machine there may be no obstructions.
- Make sure the environment of the machine is dry, clean and illuminated sufficiently.
- With the machine in operation it is forbidden to be within the operation area of this apparatus.
- Before taking the machine into operation the machine operator has to be certain that nobody is located within the operating area of the machine.
- If the machine is used into the darkness, the operation position has to be illuminated sufficiently (about 50 lux).
- The machine may only be used for the intended activities.
- Inspection and maintenance activities have to be done before operation
- During inspection and maintenance the machine may not be used for other purposes
- The local action and safety rules have to be acted upon.
- **Make sure never to walk under the robot during operation.**
- Keep electrical switch boxes closed in order to prevent contact danger.
- Never drive the machine over a cable or extension cord
- Make sure that no person stands on a cable or extension cord

## 6 OPERATORS PROCEDURE

### 6.1. Positioning of drive unit

The drive unit can be positioned in Two different ways:

#### Climbing position (A):

Push the gas spring control down with you finger while pushing the unit grip downwards. When the drive-units hinges are in a 90° angle let go of the gas spring control knob. The gas spring will lock in this position.

#### Ground movement position (B):

Push the gas spring control down with you finger while pulling the unit grip upwards. In the up position let go of the gas spring control knob. The gas spring will lock in this position



Do not attempt to climb stairs with the unit in B position. This can cause the tracks to get stuck between the chassis.

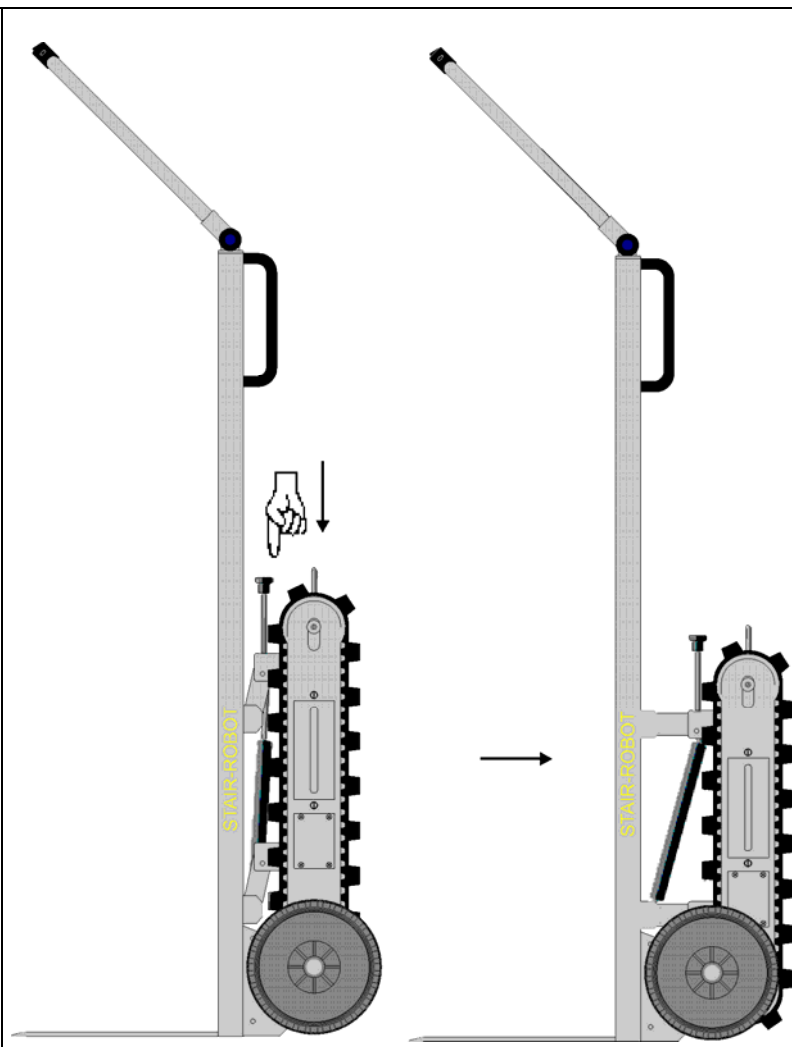

### 6.2. Controls

The SR Express is equipped with a dual control unit. One situated on top of the chassis and one on the rotatable arm.

To climb upstairs push up button; to go down push down button.

Two speed operation:

Push select button once;  
Speed (1)  
Push select button once again;  
Speed (2)

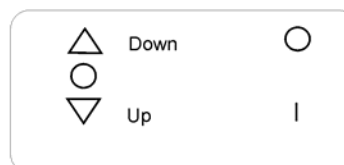
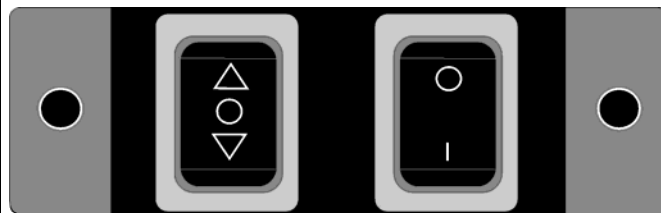

### 6.3. Rotating arm

The SR Express has a rotating arm handle that can be fixed in any position.

Fixed in 45° for use on the staircase  
In flat position and folded away for use on ground level .

The arm is fixed by a turning handle. Turn clockwise to fix and anticlockwise to release.

 Important: to avoid damage to the teeth of the hinge always fix arm tight!

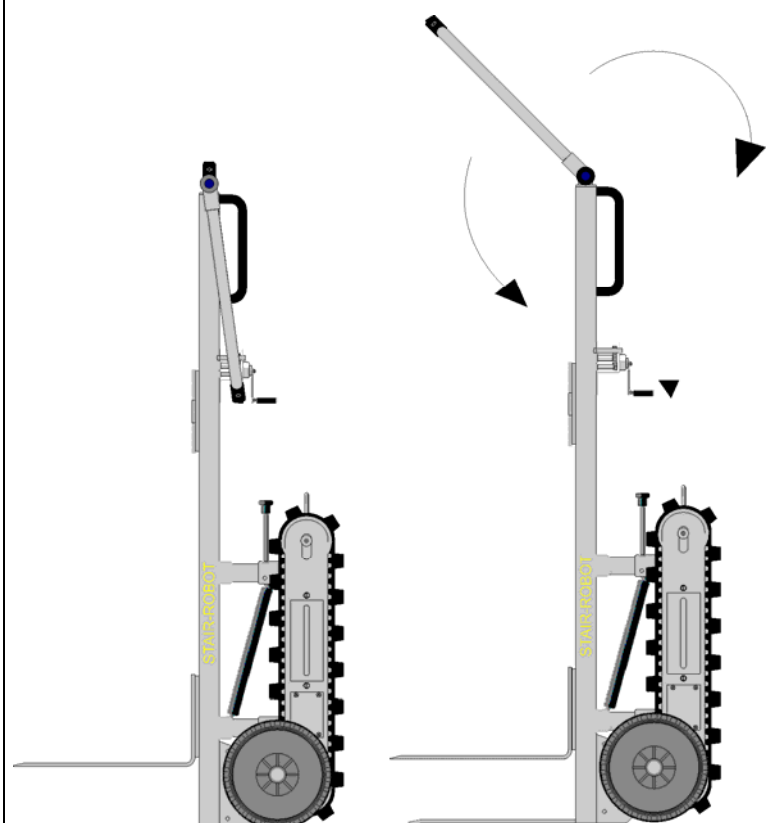

### 6.3. Pre-use inspection

To ensure proper working and safe condition of the SR Express:

- Check that no rubber blocks on the tracks are severely damaged or torn off
- Check the drive-tooth side of the tracks for exposed stringing cords or damage
- Check that nothing has been trapped between the tracks and the robot
- Check that the batteries are fully loaded (battery charge indicator)
- Check that the two fixed wheels can move free
- Check that the gas spring allows the drive unit to move up and down
- Use the controls causing the tracks to move forward and backward, listen for excessive sounds ;If a defect is found do not use the machine until the Stair-Robot is repaired.
- Check that the arm handle is fixed tight

If there are no defects found the machine is ready for use. If a defect is found do not use the machine until the Stair-Robot is repaired.

### 6.5 Loading

#### 6.5.1 The correct position of the load



- If the load is not placed in the correct position on the platform, the Stair robot can get instable during the process of climbing or descending a staircase. This can cause the robot to fall down the stairs resulting in serious damage and injuries.

- The objective is to create an optimal centre of gravity position for the loaded stairrobot considering the 'weight distribution' of the load

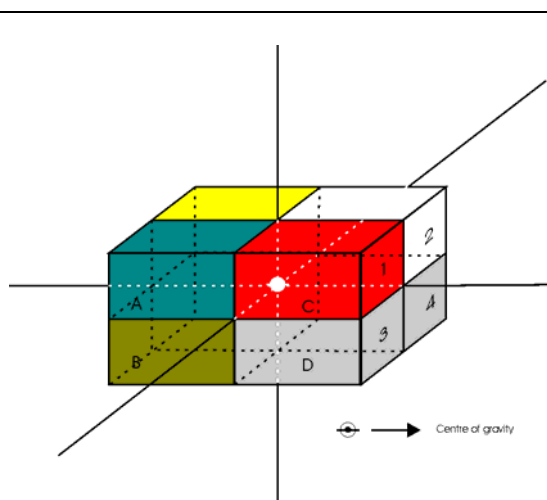

- Before positioning the load on the platform the centre of gravity of the load has to be determined

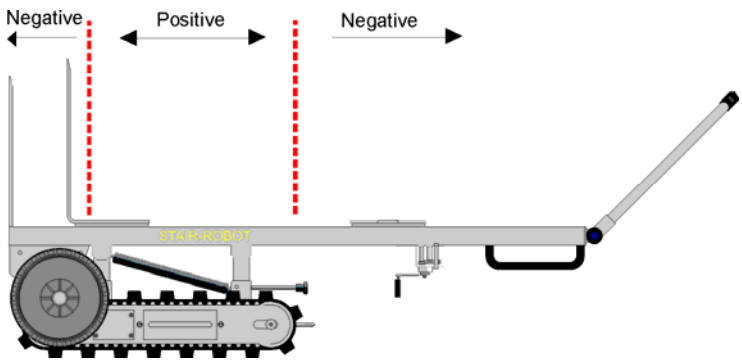
|   |   |
|---|---|
|  | <ul style="list-style-type: none"> <li>• Position the load on the platform with the centre of gravity of the load towards the front (in positive area)</li> <li>• Position the load with the centre of gravity of the load as low as possible to the lifting platform.</li> <li>• If your SR express is equipped with a lifting platform you can adjust the centre of gravity on the machine by lifting or lowering the load</li> </ul> |
|---|---|

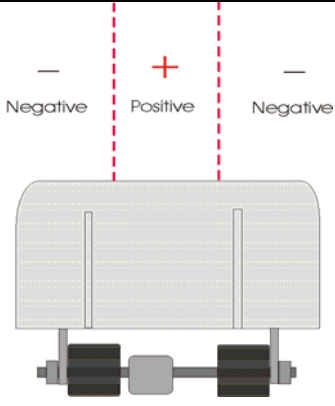
|  |  |
|--|--|
|  | <ul style="list-style-type: none"> <li>• The centre of gravity of the load should be within the positive area between the tracks.</li> </ul> |
|--|--|

### 6.5.2. Loading procedure

- Start the procedure by securing the area for loading. Move the stair robot into the desired position for loading.

The SR Express is loaded by use of the following technique:

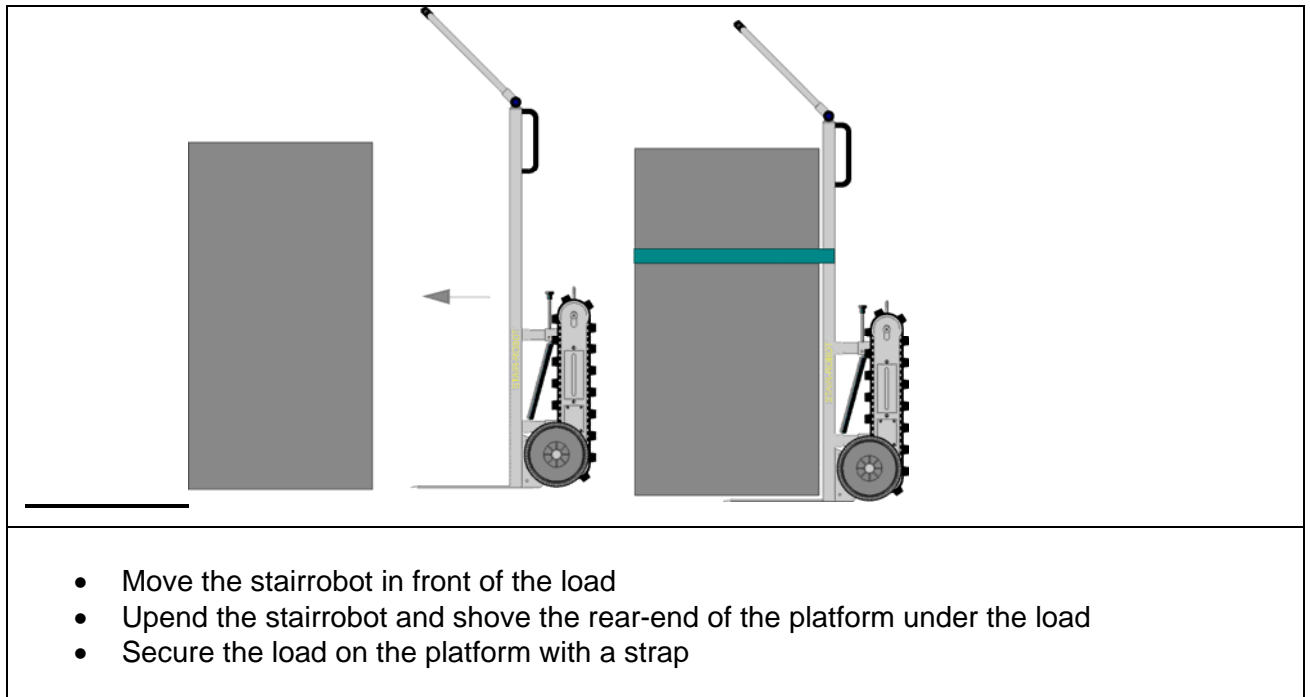

## 6.6 Ascending

There are two different techniques used to ascend a stairway:

1. Flat on a staircase as shown in picture (A)
2. Step by step as shown in picture (B)

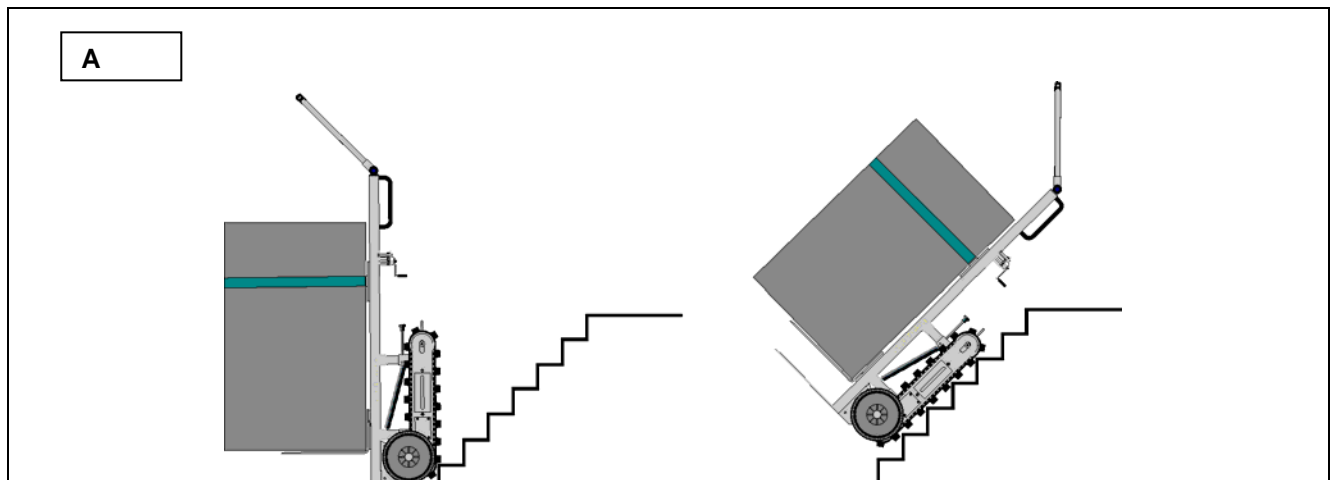

- Wheel the stairrobot to the foot of the stairway
- Lower the drive-unit in climbing position
- Make sure that the nose of the first step of the staircase is in between two blocks on the tracks. If not adjust with the forward/backward control
- Pull the stairrobot on the stairway
- Set speed to maximum (speed2)
- and use the controls to drive-up the stairway

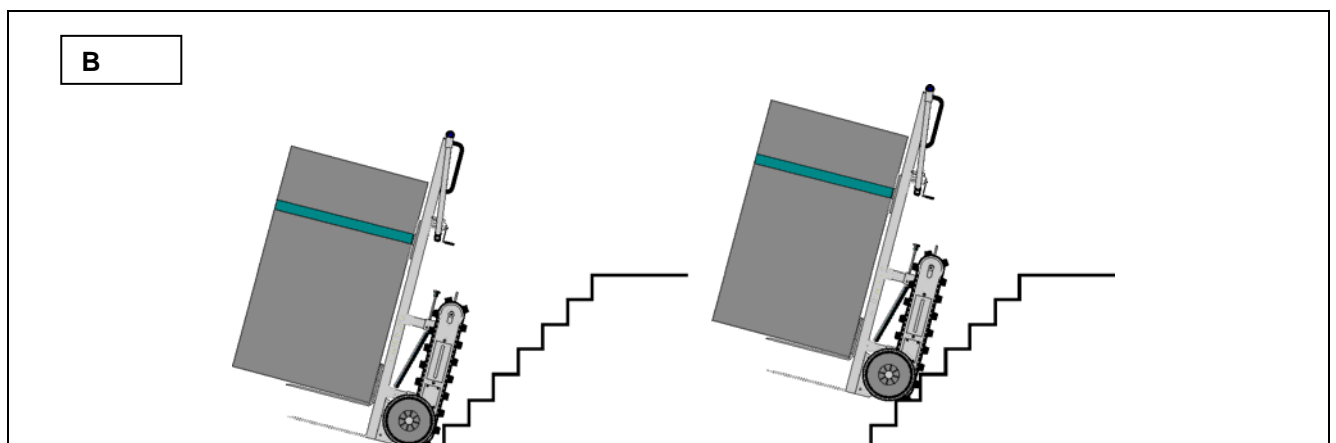

- Wheel the stairrobot to the foot of the stairway
- Lower the drive-unit in climbing position
- Make sure that the nose of the first step of the staircase is in between two blocks on the tracks. If not adjust with the forward/backward control
- Set speed to maximum (speed2)
- use the controls to drive-up the stairway while balancing the equipment in a 15° angle
- Let the SR express climb step by step
- Maximum load capacity with this technique 100 Kg.

### 6.6.1. Landing

Two techniques can be used to land the SR express on a next level:

1. Land the SR express on the air tires (drawing A)
2. Land the SR express on it's tracks (drawing B)

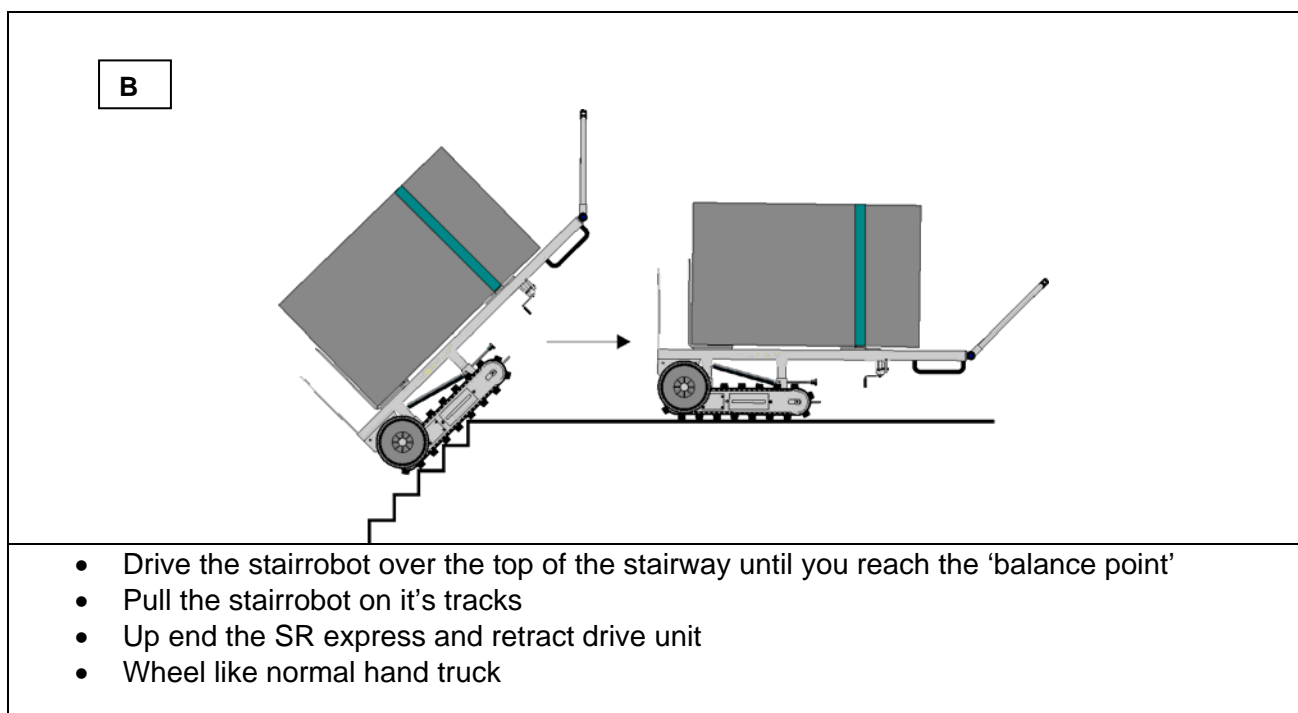
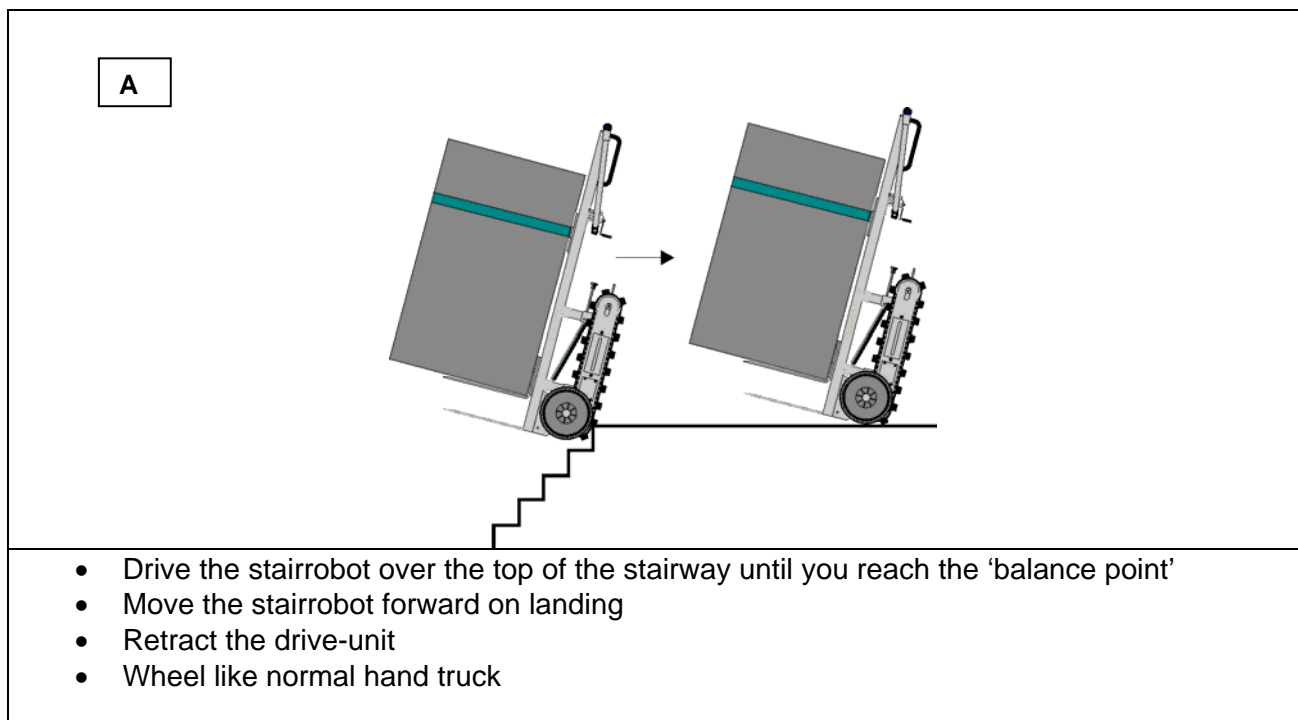

## 6.7 Descending

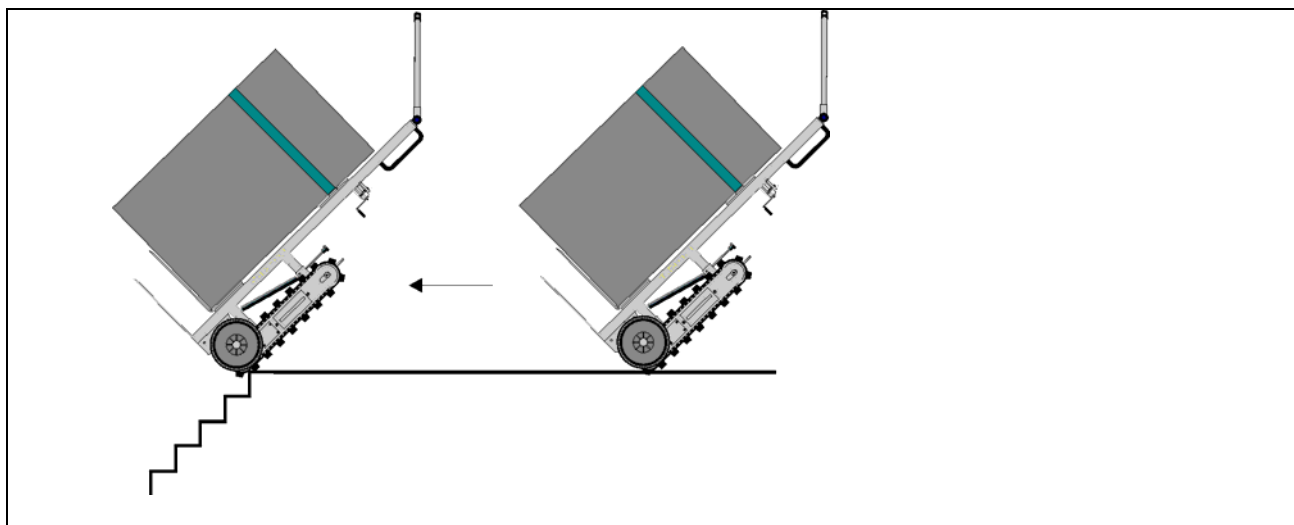

- Move the loaded stairrobot to the stairway. Stop 100 cm before the stairway and lower the drive-unit in climbing position.
- Set speed to slow (speed1) for controlled descent or speed fast (speed2) for rapid descent.
- Use the controls to move the SR express towards the staircase until the tracks have grip on the first step.
- Drive the SR express down using the controls

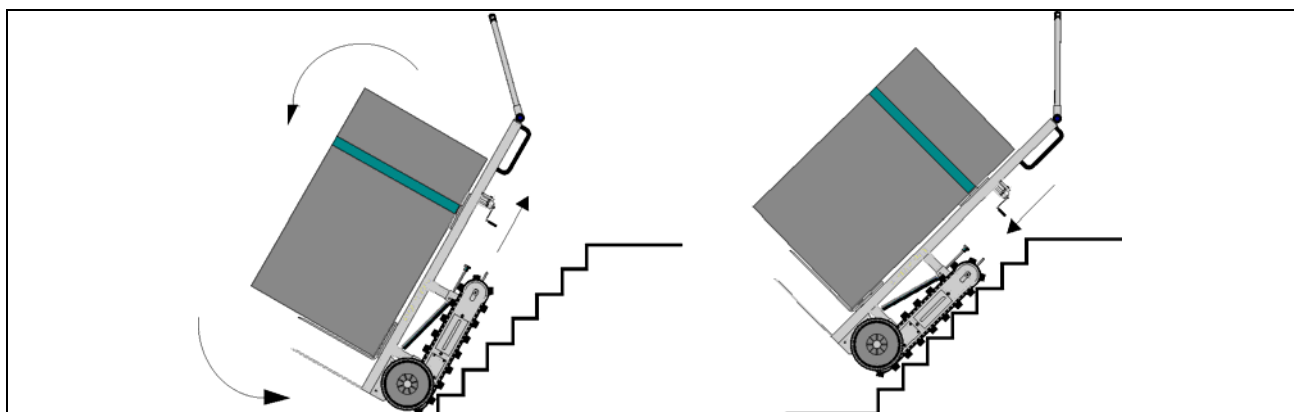

- Drive the stairrobot downstairs until the two fixed wheels hit the floor
- Use forward command on the control handle and balance the equipment into an up-end position
- Retract the drive-unit
- Wheel like standard hand truck

## 6.8. Unloading

- Start the procedure by securing the area for unloading
- Remove securing straps
- Remove the load or pull the stairrobot from under the load

|   |  |
|---|--|
|  | <ul style="list-style-type: none"><li>• All operators techniques should be practiced with a light load first</li></ul> |
|---|--|

## 7 Trouble shooting chart

The stairrobot SR 450 is designed and built to function for several years with little maintenance. In case a problem occurs please make the following checks. If the problem continues to exist please contact your local dealer

| Symptom  | Possible course  | Solution   |
|--|--|--|
| <ul style="list-style-type: none"> <li>Main motor does not work</li> </ul> | <ul style="list-style-type: none"> <li>Key switch off</li> <li>No current</li> </ul>   | <ul style="list-style-type: none"> <li>Check Fuse</li> <li>Keyswitch on</li> </ul>   |
| <ul style="list-style-type: none"> <li>Main motor stops</li> </ul>         | <ul style="list-style-type: none"> <li>Overloaded</li> <li>Motor overheated</li> <li>Climb to steep</li> <li>Battery-power to low</li> </ul> | <ul style="list-style-type: none"> <li>Use downbutton on control and restart climbing</li> <li>Check if on/of indicator led is off : replace fuse</li> <li>Charge batteries</li> </ul> |
| <ul style="list-style-type: none"> <li>Batteries do not charge</li> </ul>  | <ul style="list-style-type: none"> <li>Batteries damaged</li> <li>Battery charger is not working</li> </ul>                                  | <ul style="list-style-type: none"> <li>Replace batteries</li> <li>Replace charger</li> </ul>   |

## 8 Track replacement

- Place the stairrobot on it's tracks
- Unscrew bolt A anti-clockwise left and right
- and loosen the track stretch-bolts (B) on both sides
- Remove track
- Replace tracks with the > mark pointing on the track in the same direction and place
- Proper track tolerance in the middle of the track is +/- 8 mm (pulled by hand)

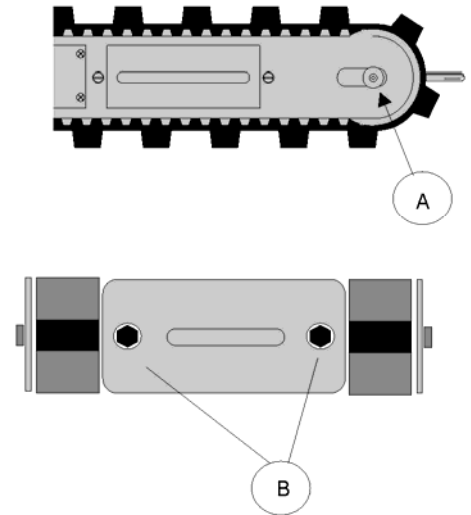

## 9. CD-Rom video

